



1 3/4" BORE ACCESSORIES



MOUNTING NUTS

Stud Nut

Part Number	Across Flats	Nut Thickness	Nut (Thread)
N16-14	1 1/2"	35/64"	1-14

Rod Nut

Part Number	Across Flats	Nut Thickness	Nut (Thread)
N07-20	11/16"	1/4"	7/16-20

CB-2495

Clevis Bracket
Material: Steel, bright zinc plated

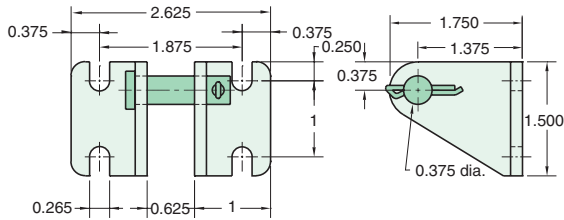

RK-2899

Replaceable Rod Seal
Material: Aluminum body

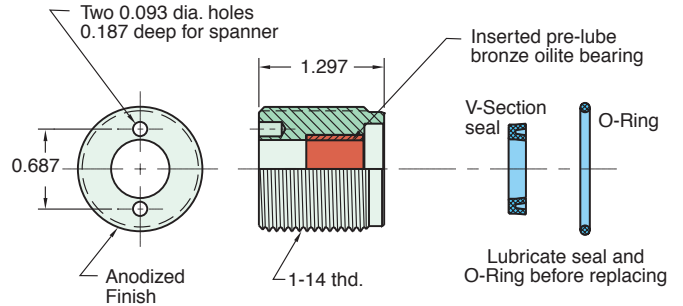

RC-3281

Rod Clevis
Material: Steel, electroless nickel plate

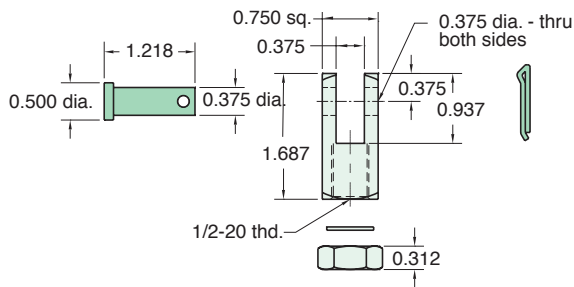

RE-3285

Rod End
Material: Steel, bright zinc plated body

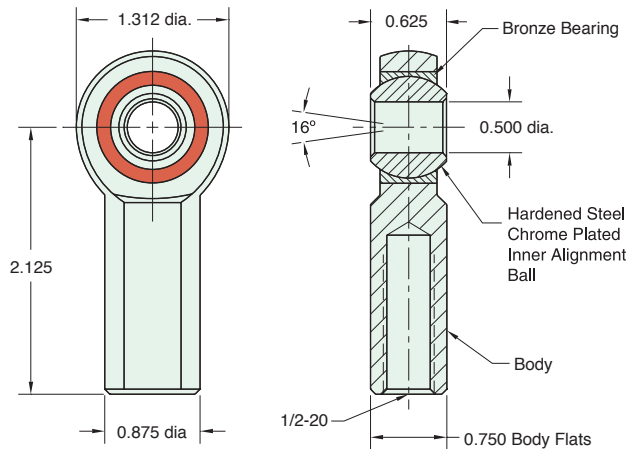

FB-2891

Foot Bracket
Material: Steel, bright zinc plated

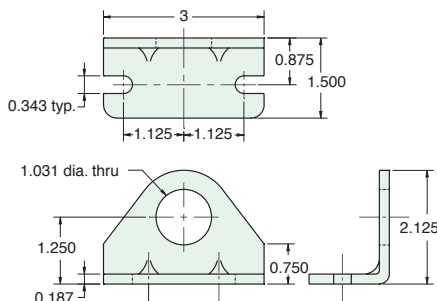

Lockwasher

Locknut

Max. Static Radial Load: 6700 lbs.
Fits Rod Thread Size: 1/2-20